

RoHS & REACH Compliant

Zero Temperature Coefficient (ZTC) Current Limiting Diodes*

*ALSO REFERRED TO AS CURRENT REGULATING DIODE



Central Semiconductor's **CDCLD series of ZTC Current Limiting Diodes** (ZTC CLDs) is specifically designed for applications requiring a constant current regulation. The ZTC CDCLD series was designed with a unique process which maintains constant current over a broad temperature range. This Zero Temperature Coefficient feature eliminates the need for additional resistors to compensate for variation in the current limit as a result of changes in temperature. The regulator current values range from 27.5mA to 575mA with a maximum limiting voltage (VL) from 1.5V to 2.0V.

Manufactured in the industry standard DPAK surface mount package, these **Industry First** devices are ideal for high intensity industrial and consumer lighting systems, as well as test/measurement equipment and standard LED applications. The complete range of devices is also available in bare die for space constrained assemblies and module applications.

Features

- Constant current range
- Temperature independence
- High stability over wide temperature range
- Nominal current regulation at low voltage input
- **Bare die coming soon**

Applications

- High intensity lighting systems
- Infrastructure lighting systems
- LED drivers
- Light dimming systems
- Test/measurement equipment

Benefits

- Eliminates need for additional resistors
- Active current source performance
- Optimized for heat dissipation

Central Part No.	Maximum Ratings (T _A = 25°C)		Electrical Characteristics (T _A = 25°C unless otherwise noted)			
	Peak Operating Voltage	Operating & Junction Storage Temperature	Regulator Current (tp=4.5ms)			Maximum Limiting Voltage (tp=5.0ms)
	P _{OV} (V)	T _J , T _{stg} (°C)	I _P @ V _T =5.0V			V _L @ I _L =0.8 x I _P MIN
			MIN (mA)	NOM (mA)	MAX (mA)	(V)
CDCLD025*	50	-55 to +150	22.5	25	27.5	1.5
CDCLD040*	50	-55 to +150	36	40	44	1.5
CDCLD080	50	-55 to +150	72	80	88	1.8
CDCLD100	50	-55 to +150	85	100	115	2.0
CDCLD120	45	-55 to +150	102	120	138	2.0
CDCLD200	27	-55 to +150	170	200	230	2.0
CDCLD400	13.5	-55 to +150	340	400	460	2.0
CDCLD500	10.8	-55 to +150	425	500	575	2.0

* Item under development.



SPICE Models, Package Details and other technical resources:

Engineering resources are available at www.centralsemi.com.

RoHS and REACH compliance declarations

Visit the Quality section of Central's website to access.

Typical Electrical Characteristics: CDCLD025 thru CDCLD120

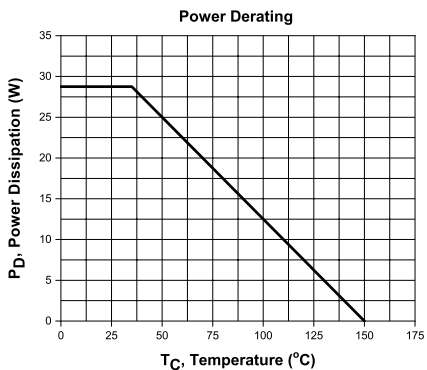
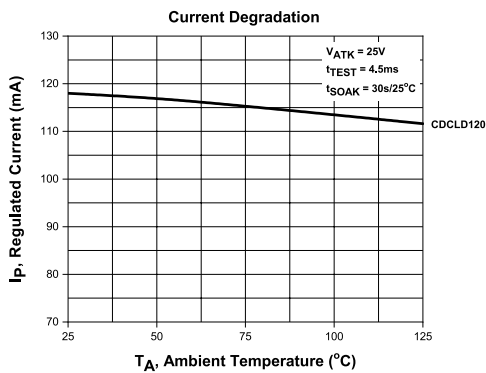
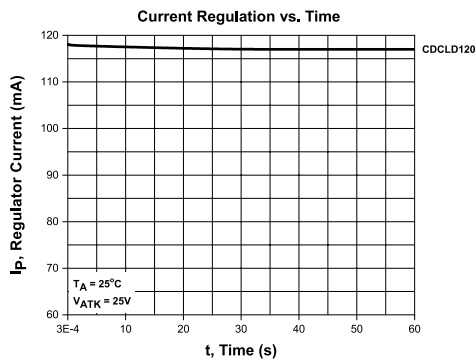
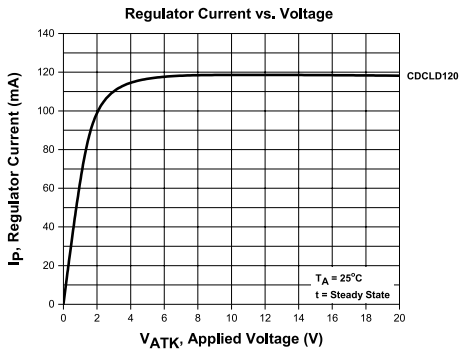

Typical Electrical Characteristics: CDCLD200 thru CDCLD500

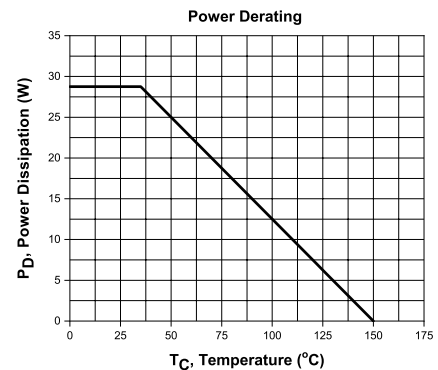
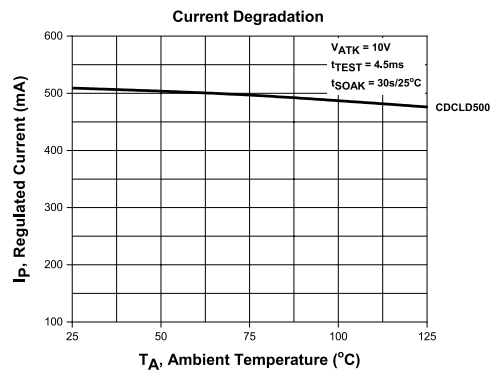
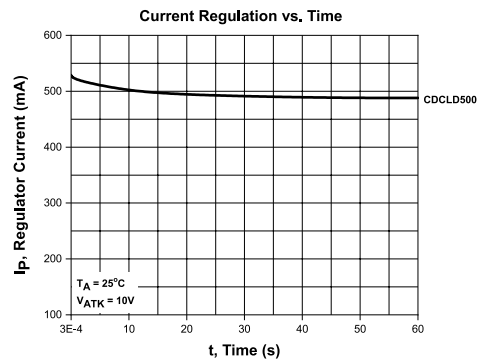
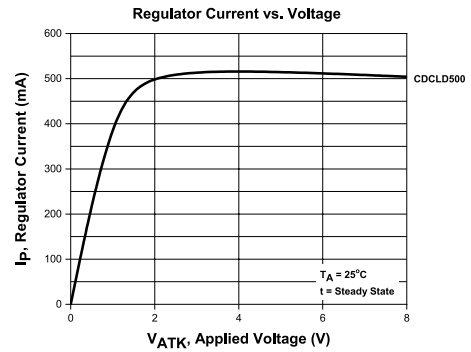

Example Applications:

LED String:

CLDs can be used to limit the current flowing through LED strings. This dynamic performance makes CLDs an excellent replacement for current limiting resistors, as they allow for continuous current regulation regardless of input voltage. LED strings like this are commonly used in dimming lighting systems. By using a PWM input to control the transistor, the LED luminosity can be controlled by extending or decreasing the pulse width, allowing for control over the brightness of the LED.

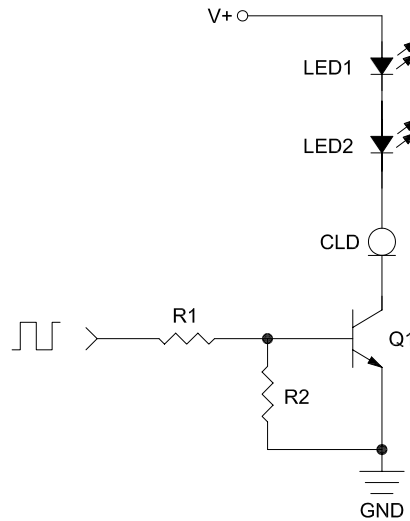

Differential Amplifier with Current Source:

When designing differential amplifiers, it is essential to use a high impedance tail resistor to control both differential and common mode function. For differential signals, the tail resistor effectively splits the current amongst the transistors. This ensures proportional current increase and decrease between the transistors. The high impedance drives down the common mode gain and increases the common mode rejection ratio, thus yielding a more ideal amplifier. Ideally, an infinite impedance current source would be used in place of the tail resistor. While the ideal current source doesn't exist, the CDCLD series serves as an excellent replacement for the tail resistor. The CDCLD CLDs perform much like an active current source, both regulating the circuit to a constant current and presenting a large tail impedance. This yields a larger CMRR than if a high impedance tail resistor is used.

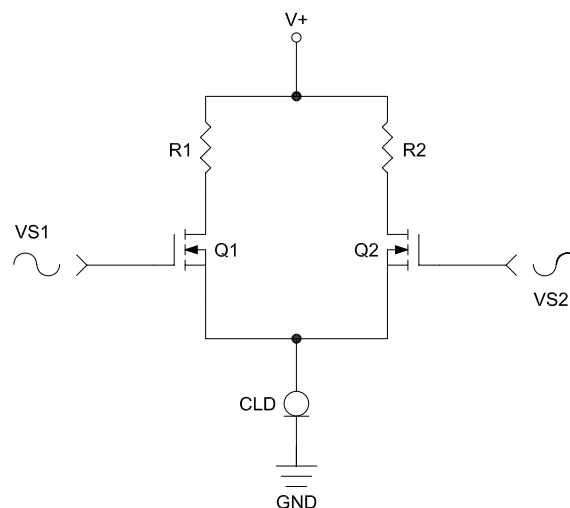

CDCLD025 Series CDCLD200 Series

Zero Temperature Coefficient
Current Limiting Diodes

Mechanical Drawing: DPAK

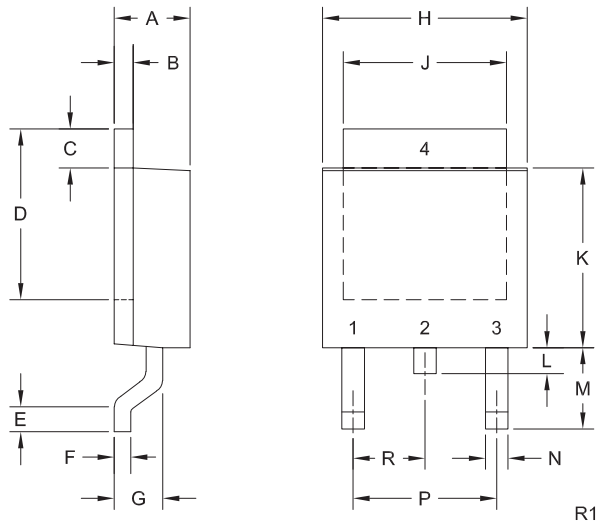

SYMBOL	INCHES		MILLIMETERS	
	MIN	MAX	MIN	MAX
A	0.083	0.108	2.10	2.75
B	0.016	0.032	0.40	0.81
C	0.035	0.063	0.89	1.60
D	0.203	0.228	5.15	5.79
E	0.020	-	0.51	-
F	0.016	0.024	0.40	0.60
G	0.051	0.071	1.30	1.80
H	0.248	0.268	6.30	6.81
J	0.197	0.217	5.00	5.50
K	0.209	0.245	5.30	6.22
L	0.025	0.040	0.64	1.02
M	0.090	0.115	2.30	2.91
N	0.012	0.045	0.30	1.14
P	0.180		4.60	

Part Marking: Full Part Number
Lead Code: Reference individual device datasheet.

Mounting Pad Geometry (Dimensions in mm)

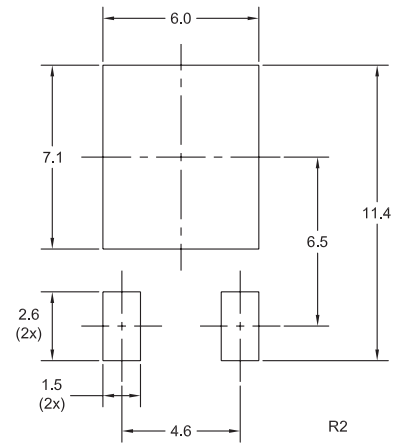

Tape Dimensions and Orientation (Dimensions in mm)

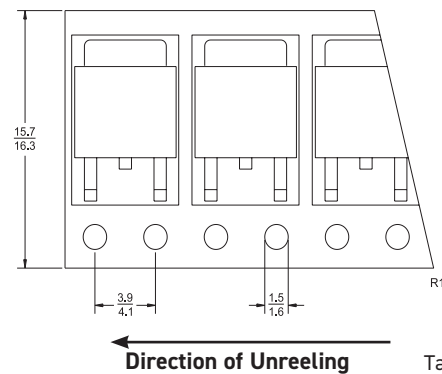

Devices are taped in accordance with Electronic Industries Association Standard EIA-481-D

Tape Width: 16mm

Packaging Base

Reel Size	Quantity
13"	2,500 pcs.

Reel Packing Information

Reel Size	Reels per Box (Max.)	Parts per Box (Max.)	Box Dimensions		Shipping Weight (Max.)	
			INCH	CM	LB	KG
13"	4	10,000	15x4x15	38x10x38	14	7
	9	22,500	15x15x9	38x38x23	29	14
	18	45,000	15x15x18	38x38x46	57	26

Ordering Information

Reel Size	Orderable Part No.
13"	Add "TR13" as suffix to Central part no. (example: CDCLD025 TR13)

For more information on Central's products and solutions:

Call us at: **1.631.435.1110**

Or view online: www.centrasemi.com/featured-products

Custom
Solutions
Available

Just
Ask