

**Package Details**  
SOD-523 Case

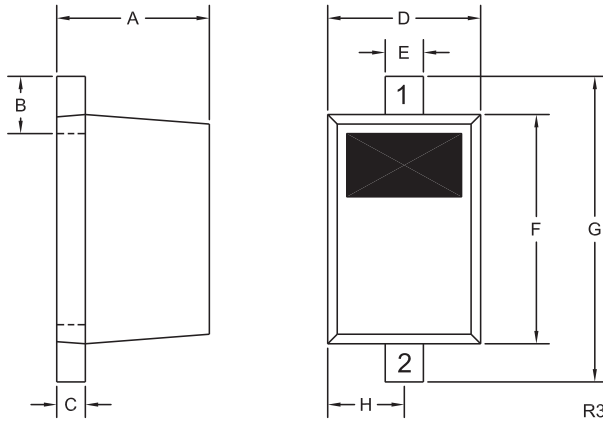

**Mechanical Drawing**



SYMBOL	INCHES		MILLIMETERS	
	MIN	MAX	MIN	MAX
A	0.020	0.031	0.50	0.80
B	0.008	0.016	0.20	0.40
C	0.002	0.008	0.05	0.20
D	0.028	0.035	0.70	0.90
E	0.008	0.014	0.20	0.35
F	0.039	0.055	1.00	1.40
G	0.055	0.071	1.40	1.80
H	0.016		0.40	

SOD-523 (REV: R3)

**Lead Code:**

- 1) Cathode
- 2) Anode

**Part Marking:** 2-3 Character Alpha/Numeric Code

**Mounting Pad Geometry** (Dimensions in mm)

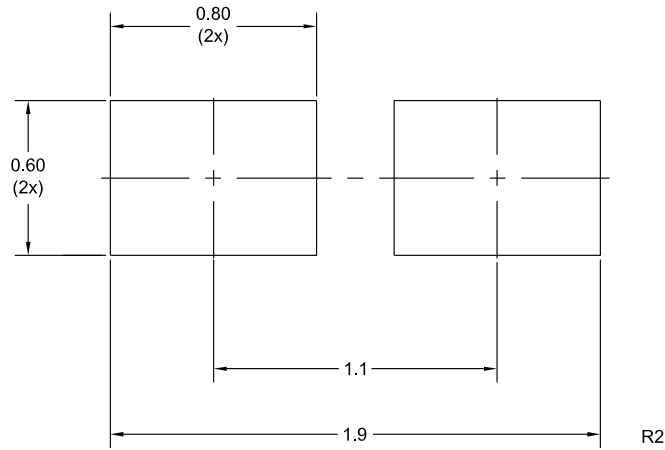

R6 (11-April 2011)

# Package Details

## SOD-523 Case



### Tape Dimensions and Orientation (Dimensions in mm)

Tape Width: 8mm

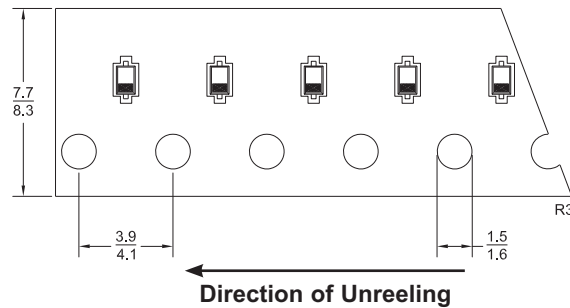

Devices are taped in accordance with Electronic Industries Association Standard EIA-481-1-A

### Packaging Base

7" Reel = 3,000 pcs.

### Reel Labeling Information

Each reel is labeled with the following information:

Central Part Number, Customer Part Number, Purchase Order Number, Quantity, Lot Number, Date Code, Ship Date and Marking Code.

### Reel Packing Information

Reel Size	Reels per Box (Maximum)	Parts per Box (Maximum)	Box Dimensions		Shipping Weight (Max.)	
			INCH	CM	LB	KG
7"	9	27,000	9x9x5	23x23x13	3	2
	18	54,000	9x9x9	23x23x23	5	3
	40	120,000	21x9x9	53x23x23	11	5
	108	324,000	27x9x17	69x23x43	30	14

### Ordering Information

- For devices taped and reeled on 7" reels, add TR suffix to part number.
- All SMDs are available in small quantities for prototype and manual placement applications.

R6 (11-April 2011)