

Package Details

DPAK Thyristor Case

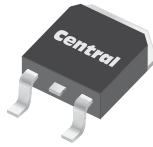

Mechanical Drawing

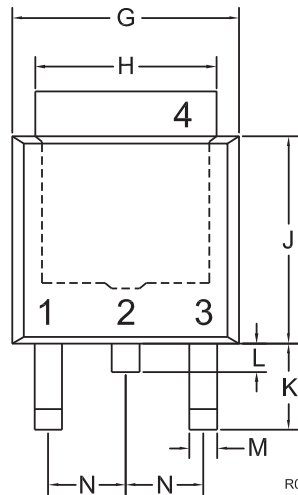
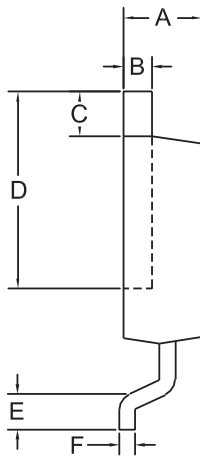

SYMBOL	INCHES		MILLIMETERS	
	MIN	MAX	MIN	MAX
A	0.086	0.094	2.18	2.39
B	0.018	0.032	0.46	0.81
C	0.035	0.050	0.89	1.27
D	0.205	0.228	5.21	5.79
E	0.047	0.055	1.20	1.40
F	0.018	0.024	0.45	0.60
G	0.250	0.268	6.35	6.81
H	0.205	0.215	5.20	5.46
J	0.235	0.245	5.97	6.22
K	0.100	0.108	2.55	2.74
L	0.025	0.040	0.64	1.02
M	0.025	0.035	0.64	0.89
N	0.090		2.28	

DPAK THYRISTOR (REV: R0)

Part Marking: Full Part Number

Lead Code:
Reference individual
device datasheet.

Mounting Pad Geometry (Dimensions in mm)

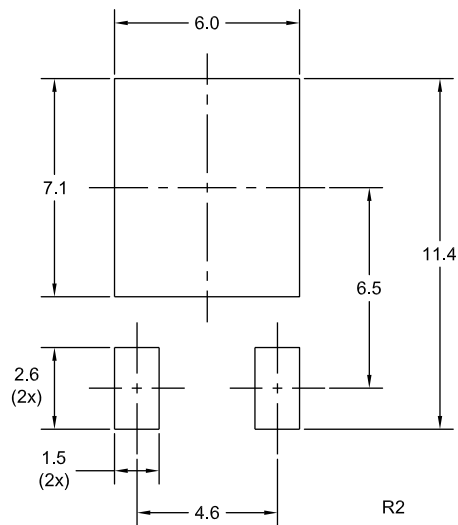

R1 (4-March 2010)

Package Details

DPAK Thyristor Case



Tape Dimensions and Orientation (Dimensions in mm)

Tape Width: 16mm

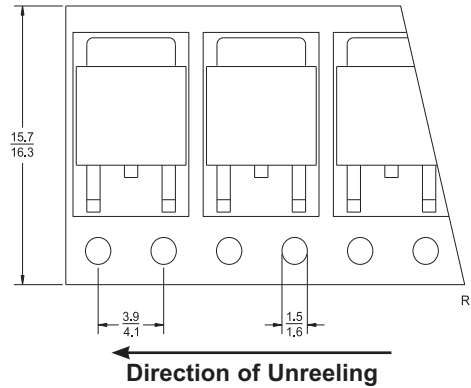

* Devices are taped in accordance with Electronic Industries Association Standard EIA-481-2-A

Packaging Base

13" Reel = 2,500 pcs.

Reel Labeling Information

Each reel is labeled with the following information:

Central Part Number, Customer Part Number, Purchase Order Number, Quantity, Lot Number, Date Code and Ship Date.

Reel Packing Information

Reel Size	Reels per Box (Maximum)	Parts per Box (Maximum)	Box Dimensions		Shipping Weight (Max.)	
			INCH	CM	LB	KG
13"	4	10,000	15x4x15	38x10x38	14	7
	9	22,500	15x15x9	38x38x23	29	14
	18	45,000	15x15x18	38x38x46	57	26

Ordering Information

- For devices taped and reeled on 13" reels, add TR13 suffix to part number.
- All SMDs are available in small quantities for prototype and manual placement applications.

R1 (4-March 2010)